

### Features

- Output voltage: 3.3V, 5V, 12V and adjustable output version
- Adjustable version output voltage range, 1.23V to 37V±4%
- 150KHz ±15% fixed switching frequency
- Voltage mode non-synchronous PWM control
- Thermal-shutdown and current-limit protection
- ON/OFF shutdown control input
- Operating voltage can be up to 40V
- Output load current: 5A
- Low power standby mode
- Built-in switching transistor on chip
- Lead Free packages: TO263-5L and TO220-5L(R)
- TO263-5L and TO220-5L(R): Available in "Green" Molding Compound (No Br, Sb)
- Lead Free Finish/RoHS Compliant (Note 1)

### General Description

The AP1501A series are monolithic ICs that are designed for a step-down DC/DC converter, and possess the ability to drive a 5A load without additional transistor component. Due to reducing the number of external component, the board space can be saved easily. The external shutdown function can be controlled by logic level and then come into standby mode. The internal compensation makes feedback control have good line and load regulation without external design. Regarding protected function, thermal shutdown is to prevent over temperature operating from damage, and current limit is against over current operating of the output switch. The AP1501A series operates at a switching frequency of 150KHz thus allowing smaller sized filter components than what would be needed with lower frequency switching regulators. Other features include a guaranteed ±4% tolerance on output voltage under specified input voltage and output load conditions, and ±15% on the oscillator frequency. The output version includes fixed 3.3V, 5V, 12V, and an adjustable type. The packages are available in a standard 5-lead TO263 and TO220 packages.

### Applications

- Simple High-efficiency step-down regulator
- On-card switching regulators
- Positive to negative converter

### Ordering Information

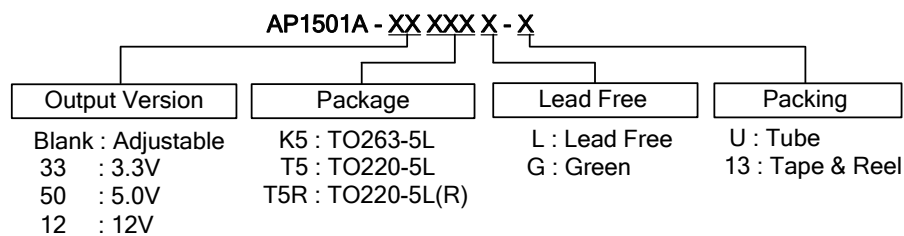

Device	Package Code	Packaging (Note 2)	Tube		13" Tape and Reel	
			Quantity	Part Number Suffix	Quantity	Part Number Suffix
AP1501A-XXK5L-U	K5	TO263-5L	50	-U	NA	NA
AP1501A-XXK5L-13	K5	TO263-5L	NA	NA	800/Tape & Reel	-13
AP1501A-XXK5G-U	K5	TO263-5L	50	-U	NA	NA
AP1501A-XXK5G-13	K5	TO263-5L	NA	NA	800/Tape & Reel	-13
AP1501A-XXT5L-U	T5	TO220-5L	50	-U	NA	NA
AP1501A-XXT5G-U	T5	TO220-5L	50	-U	NA	NA
AP1501A-XXT5RL-U	T5R	TO220-5L(R)	50	-U	NA	NA
AP1501A-XXT5RG-U	T5R	TO220-5L(R)	50	-U	NA	NA

Notes: 1. EU Directive 2002/95/EC (RoHS). All applicable RoHS exemptions applied, see *EU Directive 2002/95/EC Annex Notes*.  
 2. Pad layout as shown on Diodes Inc. suggested pad layout document AP02001, which can be found on our website at <http://www.diodes.com/datasheets/ap02001.pdf>.

### Pin Assignments

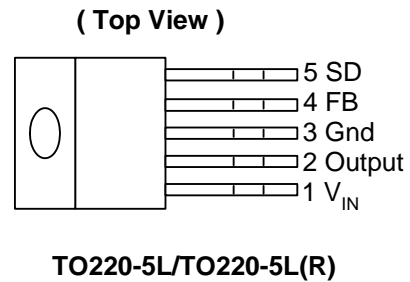
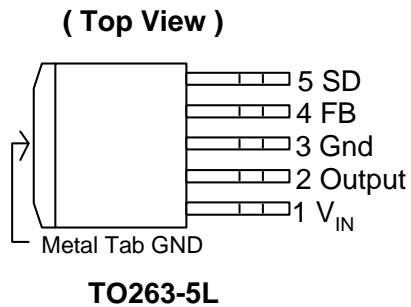

### Pin Descriptions

Name	Description
$V_{IN}$	Operating voltage input
Output	Switching output
Gnd	Ground
FB	Output voltage feedback control
SD	ON/OFF shutdown

**Block Diagram**

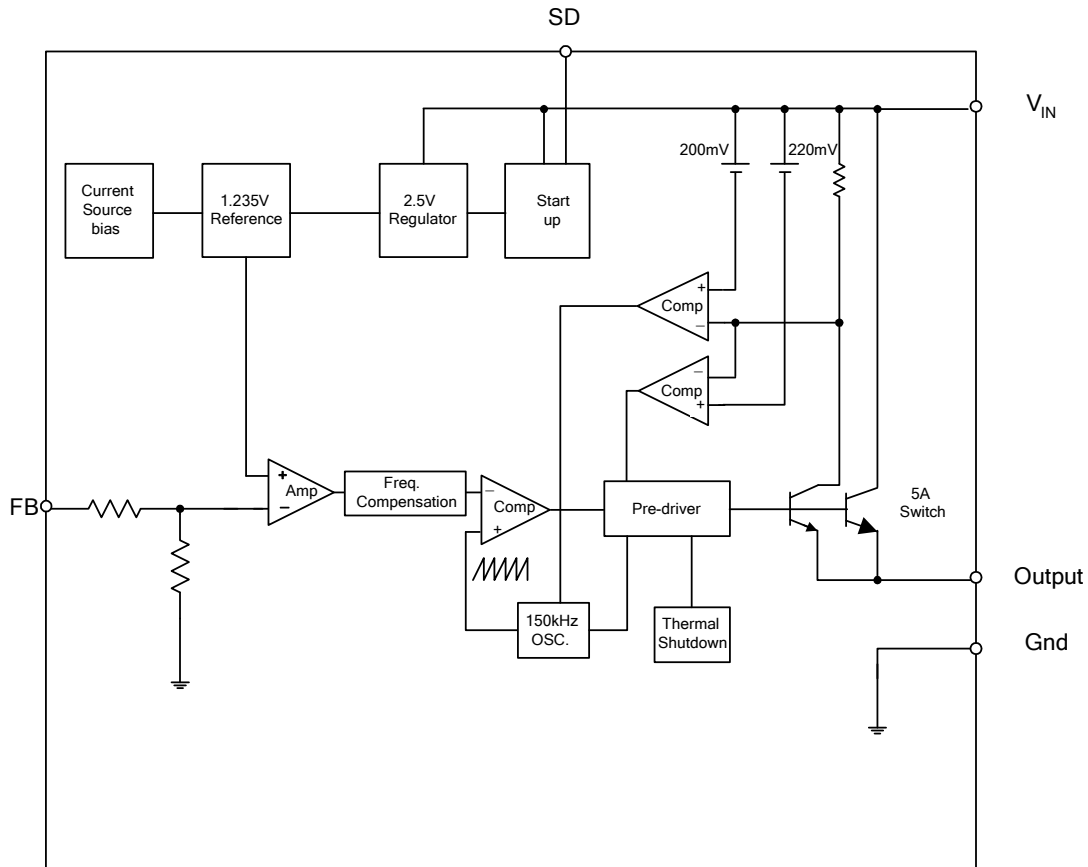

**Absolute Maximum Ratings**

Symbol	Parameter	Rating	Unit
ESD MM	Machine Model ESD Protection	400	V
V <sub>CC</sub>	Supply Voltage	+45	V
V <sub>SD</sub>	ON/OFF Pin input voltage	-0.3 to +40	V
V <sub>FB</sub>	Feedback Pin voltage	-0.3 to +40	V
V <sub>OUT</sub>	Output voltage to Ground	-1	V
P <sub>D</sub>	Power dissipation	Internally limited	W
T <sub>ST</sub>	Storage temperature	-65 to +150	°C
T <sub>J</sub>	Operating Junction Temperature	-20 to +125	°C

### Recommended Operating Conditions

Symbol	Parameter	Rating	Units
$V_{OP}$	Operating voltage	4.5 to 40	V
$T_A$	Operating Ambient Temperature	-20 to 85	°C

### Electrical Characteristics ( All Output Voltage Versions )

Unless otherwise specified,  $V_{IN} = 12V$  for 3.3V, 5V, adjustable version and  $V_{IN} = 24V$  for the 12V version.  $I_{LOAD} = 0.5A$   
 Specifications with **boldface type** are for full operating temperature range, the other type are for  $T_J = 25^\circ C$ .

Symbol	Parameter	Conditions	Min	Typ.	Max	Unit
$I_{FB}$	Feedback Bias Current	$V_{FB} = 1.3V$ (Adjustable version only)		40	60 100	nA
$F_{OSC}$	Oscillator Frequency		127 <b>110</b>	150	173 <b>173</b>	Khz
$V_{SAT}$	Saturation Voltage	$I_{OUT} = 5A$ no outside circuit $V_{FB} = 0V$ force driver on		1.5	1.6 <b>1.7</b>	V
DC	Max. Duty Cycle(ON)	$V_{FB} = 0V$ force driver on		100		%
	Min. Duty Cycle(OFF)	$V_{FB} = 12V$ force driver off		0		
$I_{CL}$	Current Limit	peak current no outside circuit $V_{FB} = 0$ force driver on	5.5	6.0	6.5 <b>7.5</b>	A
$I_L$	Output = 0V	Output Leakage no outside circuit $V_{FB} = 12$ force driver off (Note 3)			200	uA
	Output = -1V	Current $V_{IN} = 40V$		2	60	mA
$I_Q$	Quiescent Current	$V_{FB} = 12$ force driver off		5	10	mA
$I_{STBY}$	Standby Quiescent Current	ON/OFF pin = 5V		150	250	uA
		$V_{IN} = 40V$			<b>300</b>	
$V_{IL}$	ON/OFF Pin Logic Input Threshold Voltage	Low (regulator ON)		1.3	0.6	V
$V_{IH}$		High (regulator OFF)	2.0			
$I_H$	ON/OFF Pin Logic Input Current	$V_{LOGIC} = 2.5V$ (OFF)		15	25	uA
$I_L$	ON/OFF Pin Input Current	$V_{LOGIC} = 0.5V$ (ON)		0.02	5	
$\theta_{JA}$	Thermal Resistance Junction-to-Ambient	TO263-5L (Note 4)		37		°C/W
		TO220-5L(R) (Note 4)		31		
$\theta_{JC}$	Thermal Resistance Junction-to-Case	TO263-5L (Note 4)		6		°C/W
		TO220-5L(R) (Note 4)		5		

Notes: 3. Feedback pin removed from output and connected to 0V to force the output transistor switch ON. Feedback pin removed from output and connected to 12V for the 3.3V, 5V, and the ADJ. version, and 15V for the 12V version, to force the output transistor switch OFF.  
 4. Test condition: Device mounted with copper area of approximately  $3in^2$ , 1oz, no air flow.

### Electrical Characteristics (Continued)

Specifications with **boldface type** are for full operating temperature range, the other type are for  $T_J = 25^\circ\text{C}$ .

	Symbol	Parameter	Conditions	Typ.	Limit	Unit
AP1501A-ADJ	$V_{FB}$	Output Feedback	$5V \leq V_{IN} \leq 40V$ $0.2A \leq I_{LOAD} \leq 5A$ $V_{OUT}$ programmed for 3V	1.23	1.193/ <b>1.18</b> 1.267/ <b>1.28</b>	V $V_{MIN}$ $V_{MAX}$
	$\eta$	Efficiency	$V_{IN} = 12V, I_{LOAD} = 5A$	72		%
AP1501A-3.3V	$V_{OUT}$	Output Voltage	$5.5V \leq V_{IN} \leq 40V$ $0.2A \leq I_{LOAD} \leq 5A$	3.3	3.168/ <b>3.135</b> 3.432/ <b>3.465</b>	V $V_{MIN}$ $V_{MAX}$
	$\eta$	Efficiency	$V_{IN} = 12V, I_{LOAD} = 5A$	71		%
AP1501A-5V	$V_{OUT}$	Output Voltage	$8V \leq V_{IN} \leq 40V$ $0.2A \leq I_{LOAD} \leq 5A$	5	4.8/ <b>4.75</b> 5.2/ <b>5.25</b>	V $V_{MIN}$ $V_{MAX}$
	$\eta$	Efficiency	$V_{IN} = 12V, I_{LOAD} = 5A$	78		%
AP1501A-12V	$V_{OUT}$	Output Voltage	$15V \leq V_{IN} \leq 40V$ $0.2A \leq I_{LOAD} \leq 5A$	12	11.52/ <b>11.4</b> 12.48/ <b>12.6</b>	V $V_{MIN}$ $V_{MAX}$
	$\eta$	Efficiency	$V_{IN} = 16V, I_{LOAD} = 5A$	88		%

**Typical Performance Characteristics**

**Typical Performance Characteristics  
Normalized Output Voltage**

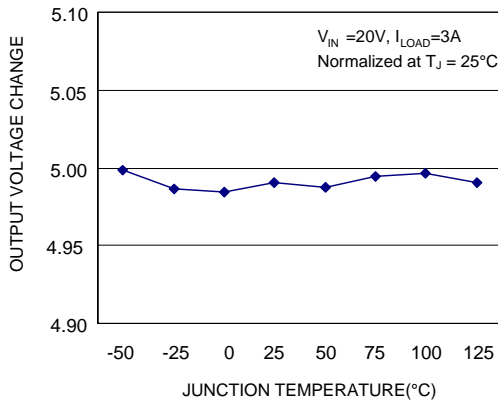

**Efficiency**

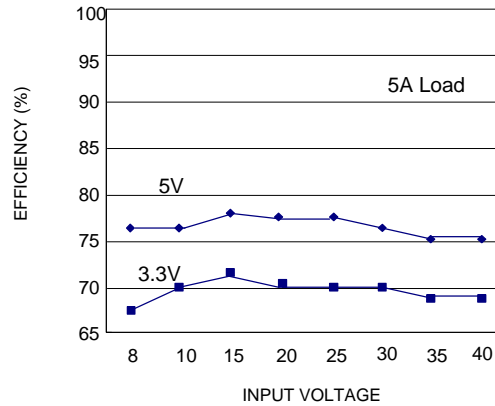

**Switch Saturation Voltage**

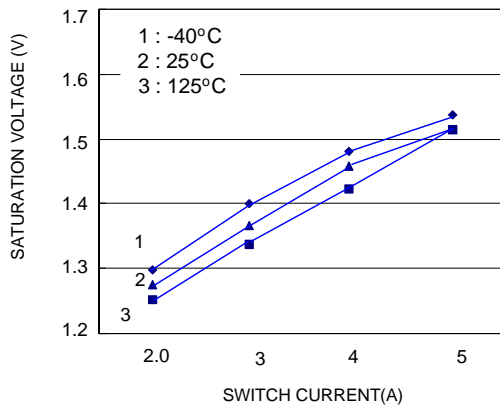

**Switch Current Limit**

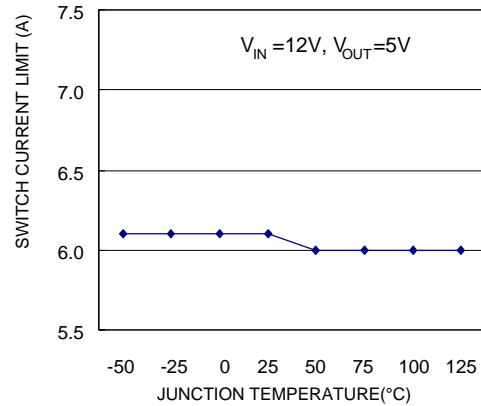

**Operating Quiescent Current**

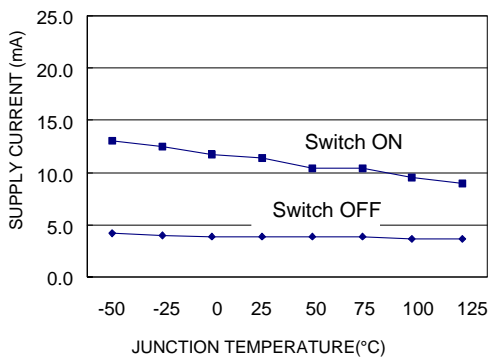

**Shutdown Quiescent Current**

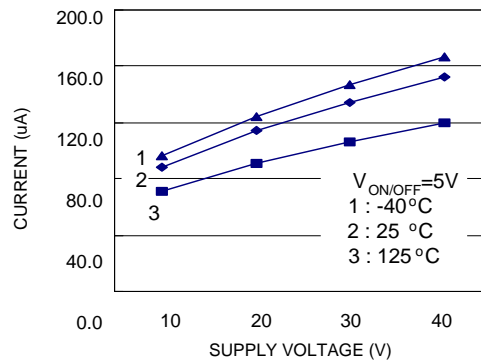

**Typical Performance Characteristics (Continued)**

**Minimum Operating Supply Voltage**

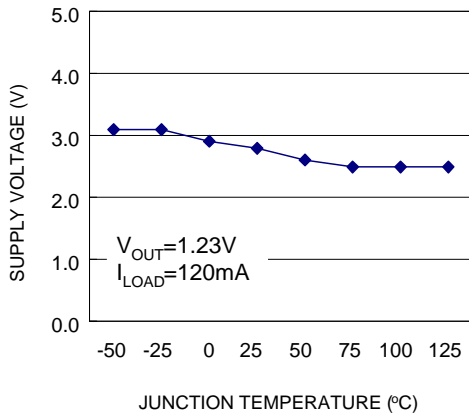

**ON/OFF Threshold Voltage**

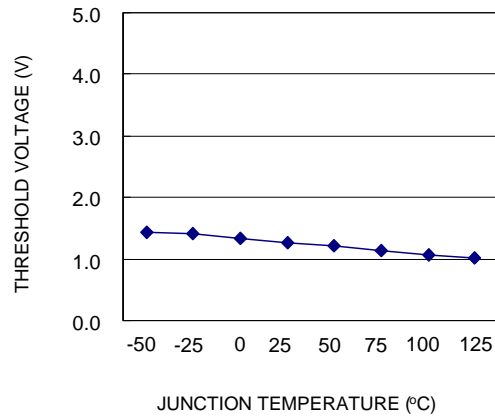

**ON/OFF Pin Current (Sinking)**

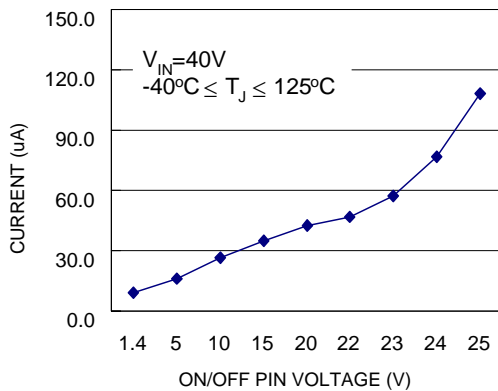

**Switch Frequency**

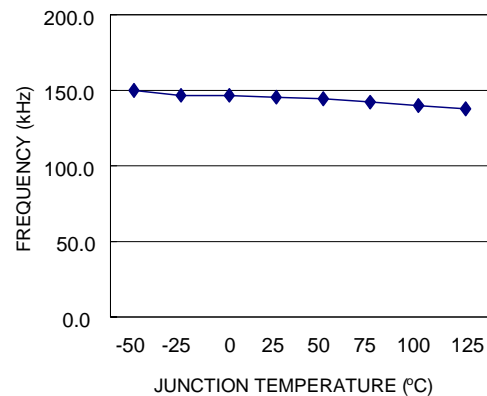

**Feedback Pin Bias Current**

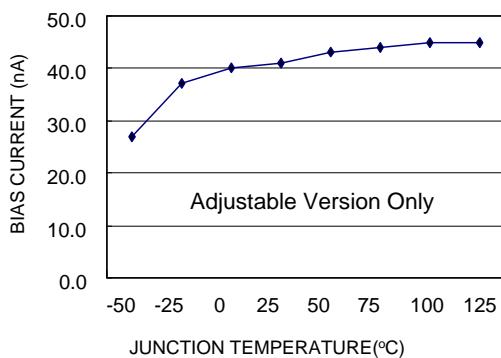

**Typical Application Circuit**

**(1) Fixed Type Circuit**

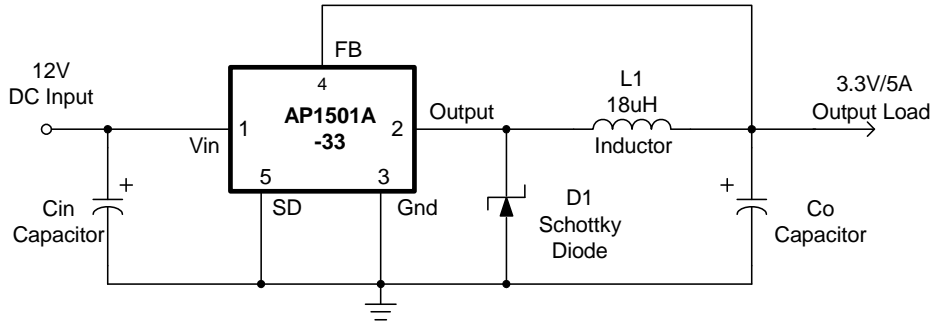

**(2) Adjustable Type Circuit**

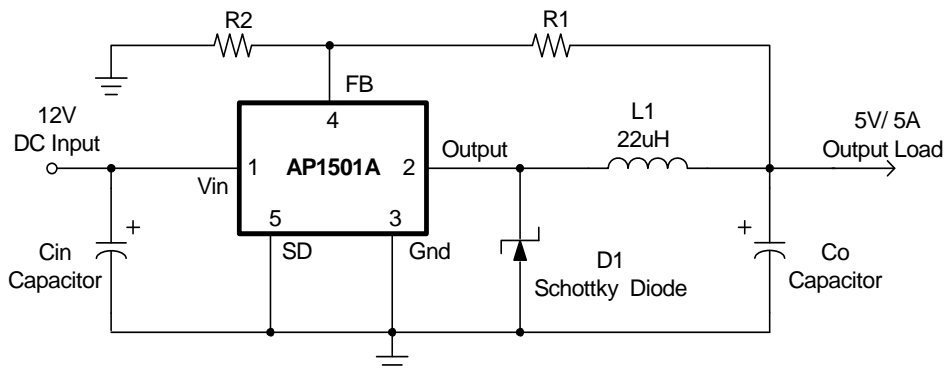

$$V_{out} = V_{FB} \times \left(1 + \frac{R1}{R2}\right)$$

$$V_{FB} = 1.23V$$

$$R2 = 1K \sim 3K$$

**(3) Delay Start Circuit**

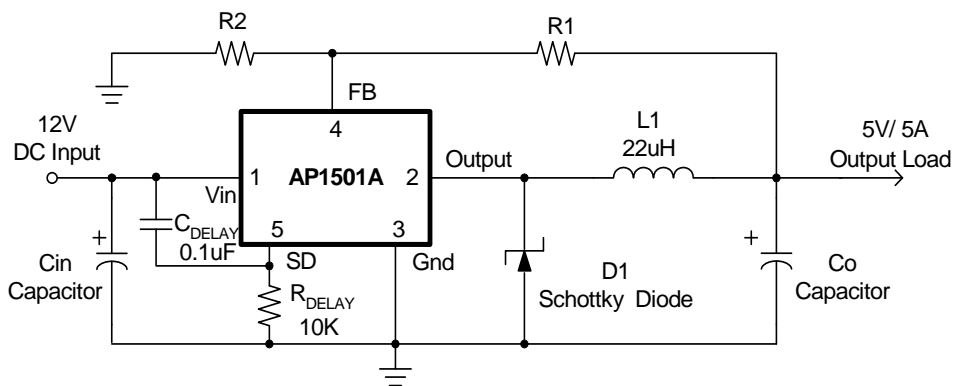



---

## Functional Description

---

### Pin Functions

#### +V<sub>IN</sub>

This is the positive input supply for the IC switching regulator. A suitable input bypass capacitor must be present at this pin to minimize voltage transients and to supply the switching currents needed by the regulator.

#### Ground

Circuit ground.

#### Output

Internal switch. The voltage at this pin switches between (+V<sub>IN</sub> - V<sub>SAT</sub>) and approximately -0.5V, with a duty cycle of approximately V<sub>OUT</sub> / V<sub>IN</sub>. To minimize coupling to sensitive circuitry, the PC board copper area connected to this pin should be kept a minimum.

#### Feedback

Senses the regulated output voltage to complete the feedback loop.

#### ON/OFF

Allows the switching regulator circuit to be shutdown using logic level signals thus dropping the total input supply current to approximately 150uA. Pulling this pin below a threshold voltage of approximately 1.3V turns the regulator on, and pulling this pin above 1.3V (up to a maximum of 40V) shuts the regulator down. If this shutdown feature is not needed, the ON/OFF pin can be wired to the ground pin or it can be left open, in either case the regulator will be in the ON condition.

#### Thermal Considerations

The AP1501A is available in two packages, a 5-pin surface mount TO-263 and TO-220.

The TO-220 package needs a heat sink under most conditions. The size of the heat sink depends on the input voltage, the output voltage, the load current and the ambient temperature. The AP1501A junction temperature rises above ambient temperature for a 5A load and different input and output voltages. The data for these curves was taken with the AP1501A (TO-220 package) operating as a buck switching regulator in an ambient temperature of 25°C (still air). These temperature rise numbers are all approximate and there are many factors that can affect these temperatures. Higher ambient temperatures require more heat sinking.

The TO-263 surface mount package tab is designed to be soldered to the copper on a printed circuit board. The copper and the board are the heat sink for this package and the other heat producing components, such as the catch diode and inductor. The PC board copper area that the package is soldered to should be at least 0.8 in<sup>2</sup>, and ideally should have 2 or more square inches of 2 oz. Additional copper area improves the thermal characteristics, but with copper areas greater than approximately 6 in<sup>2</sup>, only small improvements in heat dissipation are realized. If further thermal improvements are needed, double sided, multilayer PC boards with large copper areas and/or airflow are recommended.

The AP1501A (TO-263 package) junction temperature rise above ambient temperature with a 2A load for various input and output voltages. This data was taken with the circuit operating as a buck switching regulator with all components mounted on a PC board to simulate the junction temperature under actual operating conditions. This curve can be used for a quick check for the approximate junction temperature for various conditions, but be aware that there are many factors that can affect the junction temperature. When load currents higher than 3A are used, double sided or multilayer PC boards with large copper areas and/or airflow might be needed, especially for high ambient temperatures and high output voltages.

For the best thermal performance, wide copper traces and generous amounts of printed circuit board copper should be used in the board layout. (Once exception to this is the output (switch) pin, which should not have large areas of copper.) Large areas of copper provide the best transfer of heat (lower thermal resistance) to the surrounding air, and moving air lowers the thermal resistance even further.

Package thermal resistance and junction temperature rise numbers are all approximate, and there are many factors that will affect these numbers. Some of these factors include board size, shape, thickness, position, location, and even board temperature. Other factors are, trace width, total printed circuit copper area, copper thickness, single or double-sided, multilayer board and the amount of solder on the board. The effectiveness of the PC board to dissipate heat also depends on the size, quantity and spacing of other components on the board, as well as whether the surrounding air is still or moving.

Furthermore, some of these components such as the catch diode will add heat to the PC board and the heat can vary as the input voltage changes. For the inductor, depending on the physical size, type of core material and the DC resistance, it could either act as a heat sink taking heat away from the board, or it could add heat to the board.

**Marking Information**

(1) TO263-5L

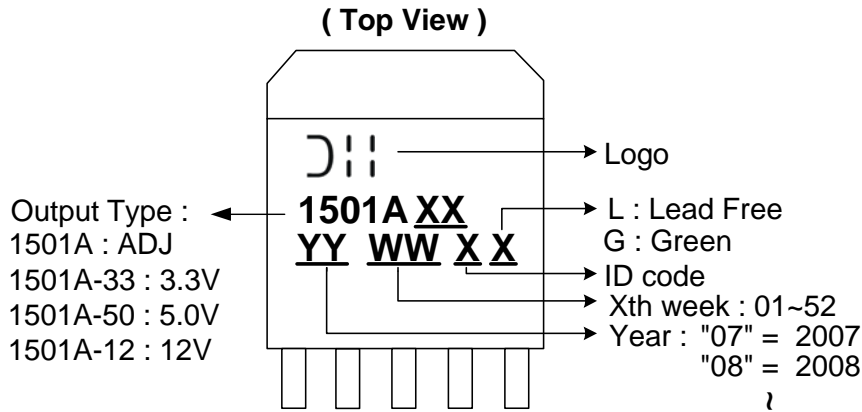

(2) TO220-5L(R)

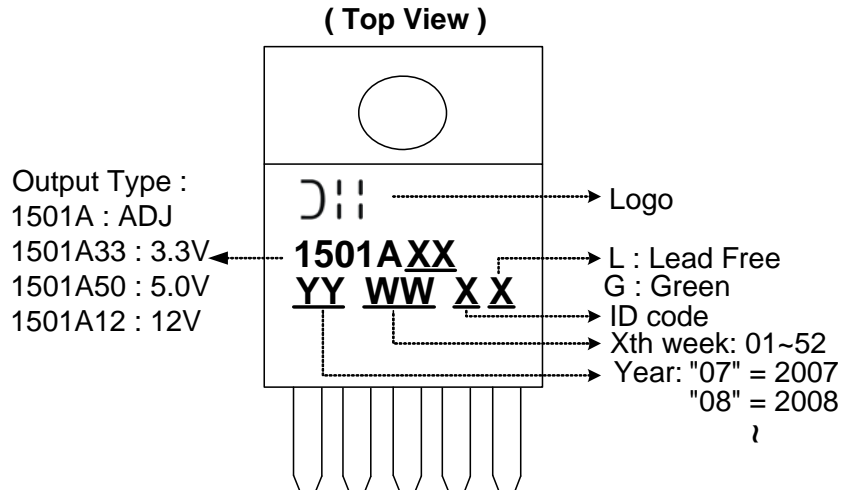

**Package Information (All Dimensions in mm)**

**(1) Package Type: TO263-5L**

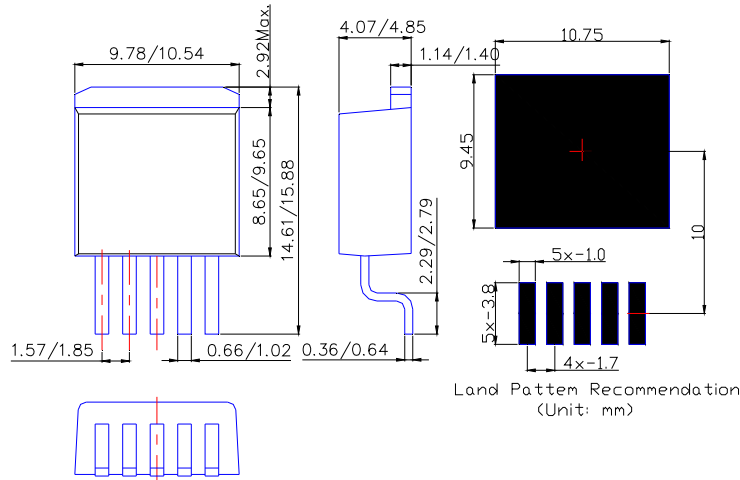

**(2) Package Type: TO220-5L**

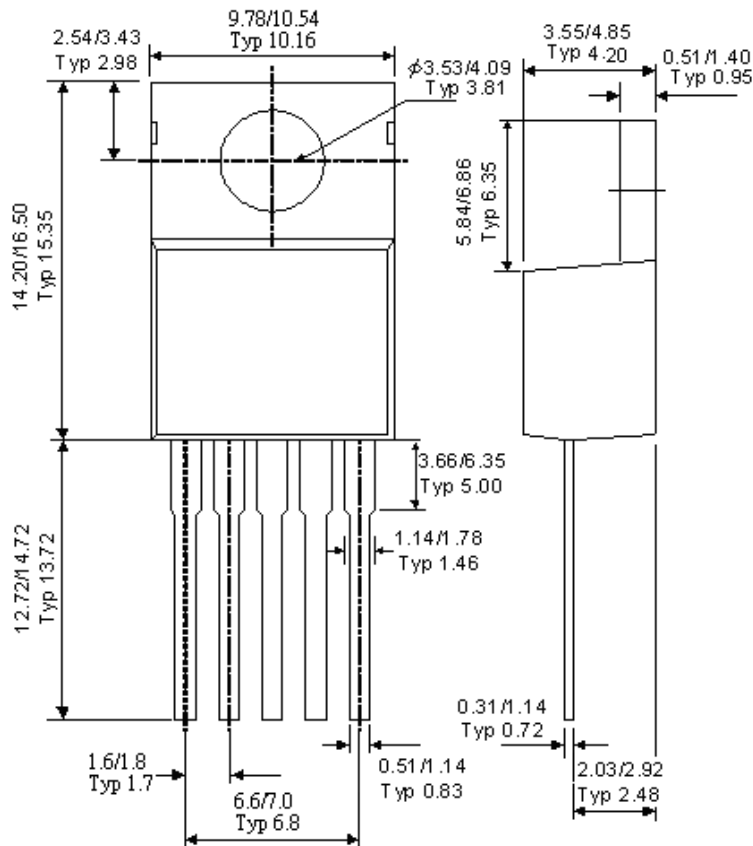

**Package Information (Continued)**

**(3) Package Type: TO220-5L(R) Mechanical drawing**

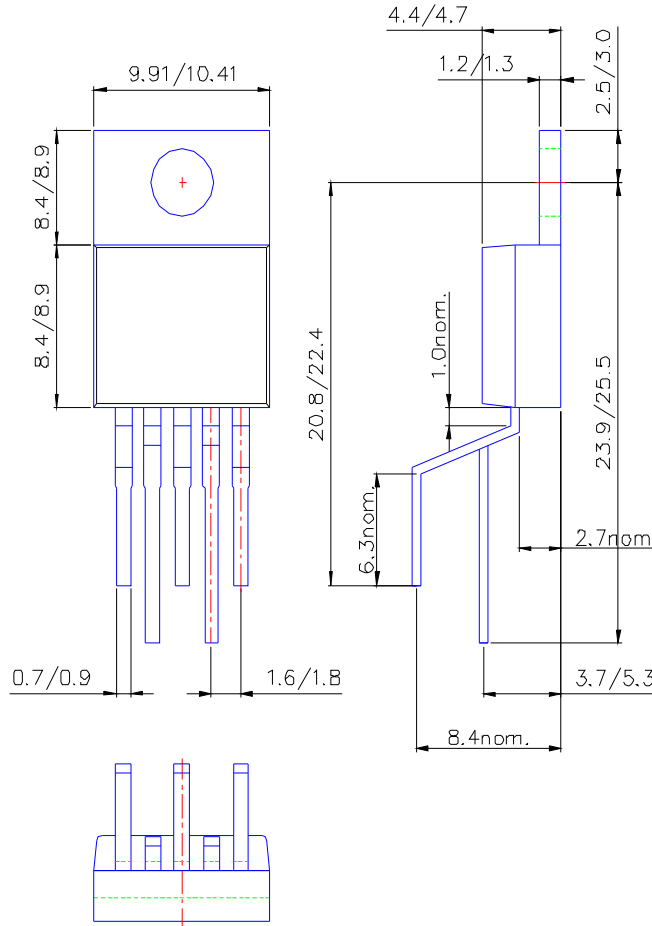

**IMPORTANT NOTICE**

Diodes Incorporated and its subsidiaries reserve the right to make modifications, enhancements, improvements, corrections or other changes without further notice to any product herein. Diodes Incorporated does not assume any liability arising out of the application or use of any product described herein; neither does it convey any license under its patent rights, nor the rights of others. The user of products in such applications shall assume all risks of such use and will agree to hold Diodes Incorporated and all the companies whose products are represented on our website, harmless against all damages.

**LIFE SUPPORT**

Diodes Incorporated products are not authorized for use as critical components in life support devices or systems without the expressed written approval of the President of Diodes Incorporated.